

Handschweißbrenner Welding Torch

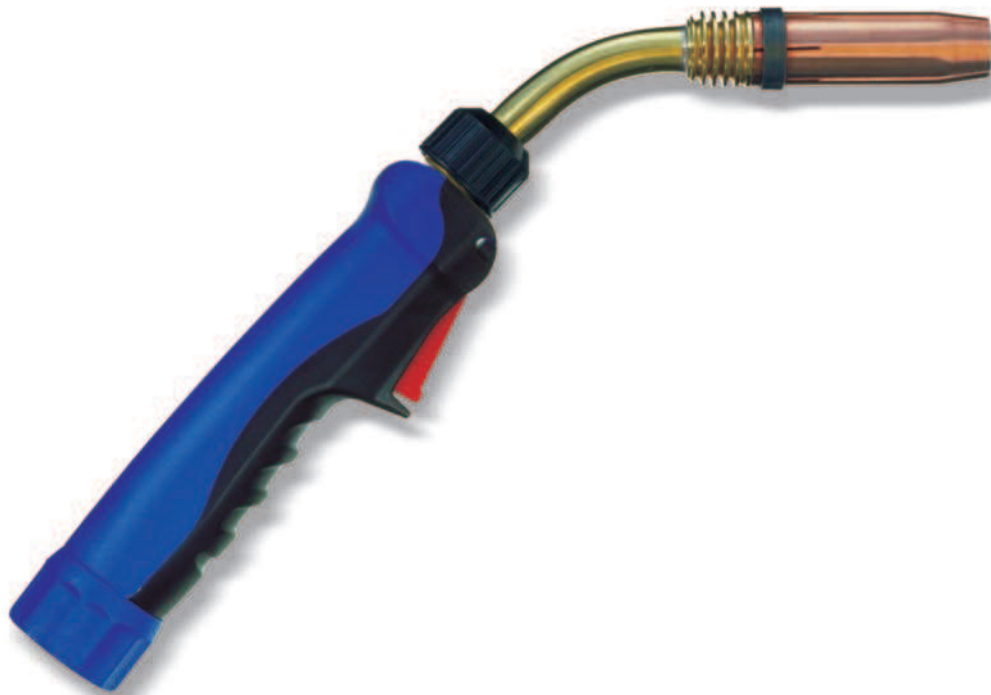

Technische Daten: SB 360 D

Belastung: 300 A CO₂ (nach EN 60 974-7)
270 A ArCO₂ / M21
Einschaltdauer: @ 60%
Draht-ø: 0,8 - 1,2 mm

Artikel Nr. / Einzelheiten	3 m	4 m	5 m
Ergo-Griff	2373030	2374030	2375030
Ergo-Griff mit Federschalter	2373050	2374050	2375050
Ergo-Griff, ZA-Stecker mit Federpins	2373230	2374230	2375230

Technical Data: SB 360 D

Rating: 300 A CO₂ (accor. to EN 60 974-7)
270 A ArCO₂ / M21
Duty Cycle: @ 60%
Wire Diameter: 0.8 - 1.2 mm

Part Number / Details	3 m	4 m	5 m
Ergo-Handle	2373030	2374030	2375030
Ergo Bladeswitch Handle	2373050	2374050	2375050
Ergo-Handle and Spring Loaded Pins	2373230	2374230	2375230

Handschweißbrenner Welding Torch

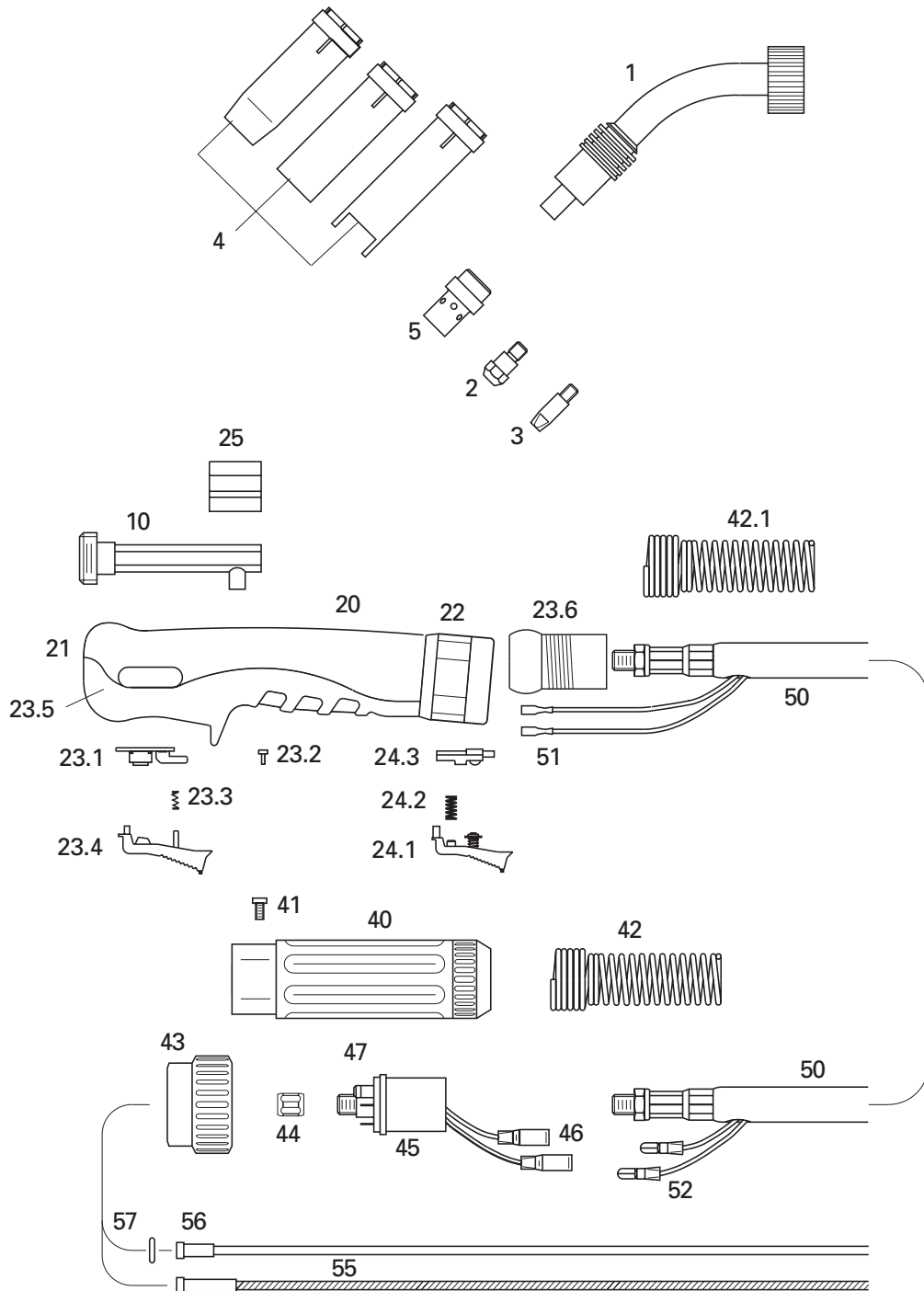

1	Brennerbauteile Torch Components	Brennerhals Swan Neck	2370100	
2		Düsenstock M 6, kurz Tip Adapter M 6, short	2360406	142.0005
		Düsenstock M 6, lang Tip Adapter M 6, long	2360416	142.0011
		Düsenstock M 8, kurz Tip Adapter M 8, short	2360408	142.0020
		Düsenstock M 8, lang Tip Adapter M 8, long	2360418	142.0024
3	Kontaktdüsen Contact Tips	M 6 x 28, ø in mm / ECu M 6 x 28, ø in mm / CuCrZr M 6 x 28, ø in mm / für / for Alu Stromdüsen erhältlich in ø 0.8/0.9/1.0/1.2/1.4/1.6 mm Bitte bei xx Drahtdurchmesser angeben. Beispiel: ø 1,2 mm ist: 12; Art.-Nr.: = 2250612 Tips available in 0.30"/0.35/0.39"/0.45"/0.52/ 1/16". Please insert wire diameter at xx. Example: ø 0.45" = 1.2 mm is 12; Art.-No.: = 2250612	22506xx 22576xx 22566xx	
140.0051, 140.0242, 140.0379, 140.0054, 140.0245, 140.0382, 141.0001, 141.0006, 141.0010				
4	Gasdüsen Gas Nozzles	Gasdüse, zylindrisch Gas Nozzle, cylindrical	2360801	145.0045
		Gasdüse, konisch Gas Nozzle, conical	2360802	145.0078
		Gasdüse, stark konisch Gas Nozzle, tapered	2360803	145.0126
		Punktgasdüse Spot Welding Nozzle	2360805	145.0172
5		Gasverteiler, weiß Gas Diffuser, white	2360702	014.0261
		Gasverteiler, schwarz Gas Diffuser, black	2360700	
10		Innenkörper für Ergo-Griff Torch Body for turnable Swan Neck, Ergo-Handle	2370101	
20		Ergo-Griff kpl. Ergo-Handle cpl.	2111100	
21		Ergo-Griff, obere & untere Hälfte & Mutter Ergo-Handle Shells with Nut	2111101	

22	Mutter Handle Nut	2111123
23.1	Schalterplatine PC Board	2111103
23.2	Schraube für Platine Screw for PCB	2111104
23.3	Feder Spring	2111105
23.4	Drücker Trigger	2111106
23.5	Schraube Screw	2101101
23.6	Knickschutz-Kugelgelenk Swivel	2111175
24.1	Taster, Ergo-Federdrücker Trigger, Ergo-Blade-Switch	2111151
24.2	Feder, Ergo-Federdrücker Spring, Ergo-Blade-Switch	2111152
24.3	Kontakthalter, Ergo-Federdrücker Contact Holder, Ergo-Blade-Switch	2111153
25	Anschlußkörper, für separates Gas Connection Body for separat gas	2150307
40	Knickschutz 2-teilig Gun Plug Housing	2251601
41	Schraube Screw	0040601
42	Knickschutzfeder Cable Support Spring	2151201
42.1	Knickschutzfeder Cable Support Spring	2111191
43	Anschlußmutter Plug Nut	2151700
44	Ms-Überwurfmutter Liner Positioner Nut	2151501

45		ZA-Stecker Luft Gun Plug Body, air cooled (Euro)	2151500	
		ZA-Stecker Luft mit Federpins Gun Plug Body with Spring Loaded Pins	2151505	
46		Rundsteckbuchse, isoliert Female Electrical Connector, insulated	2155100	
47		O-Ring / O-Ring	0041000	
50	Koaxialkabel Coaxial Cable	50 mm ² , 3 m	3005030	
		50 mm ² , 4 m	3005040	
		50 mm ² , 5 m	3005050	
51		Flachhülse 2.8 x 0.8 Female Electrical Connector	2415304	
52		Rundstecker, isoliert Male Electrical Connector, insulated	2155200	
55		DF-Spiralen ummantelt und Teflonseelen Coated Steel- and Teflon-Liners		
		DF-Spirale 1,5 x 4,0 mm / 3 m Steel Liner 1.5 x 4.0 mm / 3 m	3441530	124.0011
		DF-Spirale 1,5 x 4,0 mm / 4 m Steel Liner 1.5 x 4.0 mm / 4 m	3441540	124.0012
		DF-Spirale 1,5 x 4,0 mm / 5 m Steel Liner 1.5 x 4.0 mm / 5 m	3441550	124.0015
		Teflonseele 1,5 x 4,0 mm / 3 m Teflon Liner 1.5 x 4.0 mm / 3 m	3411530	126.0005
		Teflonseele 1,5 x 4,0 mm / 4 m Teflon Liner 1.5 x 4.0 mm / 4 m	3411540	126.0008
		Teflonseele 1,5 x 4,0 mm / 5 m Teflon Liner 1.5 x 4.0 mm / 5 m	3411550	126.0011
		DF-Spirale 2,0 x 4,0 mm / 3 m Steel Liner 2.0 x 4.0 mm / 3 m	3442030	
		DF-Spirale 2,0 x 4,0 mm / 4 m Steel Liner 2.0 x 4.0 mm / 4 m	3442040	
		DF-Spirale 2,0 x 4,0 mm / 5 m Steel Liner 2.0 x 4.0 mm / 5 m	3442050	
		Teflonseele 2,0 x 4,0 mm / 3 m Teflon Liner 2.0 x 4.0 mm / 3 m	3412030	126.0021
		Teflonseele 2,0 x 4,0 mm / 4 m Teflon Liner 2.0 x 4.0 mm / 4 m	3412040	126.0026
		Teflonseele 2,0 x 4,0 mm / 5 m Teflon Liner 2.0 x 4.0 mm / 5 m	3412050	126.0028

56	Haltenippel für ummantelte Spirale 4,0 Collet for coated Liner 4.0	2155640
	Haltenippel für Teflonseele 4,0 Collet for Teflon Liner 4.0	2155740
57	O - Ring O - Ring	0031500

Fehlerbehebung

- | | |
|--------------------------------|---|
| 1.) Schlechter Drahtvorschub: | Spirale verstopft oder geknickt. Falsche Größe von Spirale oder Stromdüse. Spirale zu kurz und liegt nicht korrekt am Düsenstock an. |
| 2.) Brennerüberhitzung: | Lose Verbindung am Zentralanschluß. Brenner wird mit zu hoher Amperezahl geschweißt. Zu gering bemessenes Massekabel. |
| 3.) Poröse Schweißnaht: | Spritzer in der Gasdüse behindern den Gasdurchfluß. Lose Verbindung von Gasschlauch oder Leck im Gasschlauch. O-Ringe am Zentralanschluß sind lose oder beschädigt. |
| 4.) Kurze Stromdüsenstandzeit: | Drahtvorschubrollen sind zu eng angezogen und verursachen Riefen am Schweißdraht. Der Schweißdraht ist schmutzig oder rostig. Falsche Stromdüsendurchmesser. Brenner wird zu hoch belastet. |

Trouble Shooting

- | | |
|----------------------|---|
| 1.) Poor Wire Feed: | Liner clogged or kinked. Incorrect liner size or contact tip. Liner cut too short and not seating properly in tip adapter. |
| 2.) Gun Overheating: | Loose connection at the wire feeder. Gun being run beyond its amperage. Insufficient gauge power cable or ground cable. |
| 3.) Weld Porosity: | Spatter built up in nozzle blocking gas. Leaks in gas hose or improper connection. Conductor tube loose from adapter block or O-Rings at plug are cut or damaged. |
| 4.) Short Tip Life: | Drive rolls too tight resulting in scoring of weld wire. Welding wire dirty, rusty or too much cast. Wrong tip size. Torch over rated duty cycle. |



Fax: +43 7682 21718 17 4870 Vöcklamarkt
 Tel.: +43 664 88512370 E-Mail: office@wal-austria.at
 Schmidham 26 www.wal-austria.at

Schneiden - Spannen - Schweißen in Perfektion